



**2011**

## Annual Meeting & Election Flyer



WWW.NMSSA.ORG

NEW MEXICO SHOOTING SPORTS ASSOCIATION

# New Mexico Shooting News

## Presidents Input By Anthony Trennel President, NMSSA

The annual meeting, January 15, 2011 will begin at 9am, guest and member speakers will start after the introduction followed by the business meeting, likely after lunch. One of our speakers will be Sen. George Munoz, Gallup who is following NM game law aberrations. Other speakers are being lined up for the morning session.

There are several issues to discuss during the business meeting. One of the main issues is setting up several shoots during the year with one having an executive meeting associated with it. I would like to do a shoot at Whittington Center, perhaps silhouette and other shooting which is available such as trap and skeet at very reasonable prices. Overnight stays at the center are very reasonable and the drive to town is 10-15 minutes.

Board members and officers are asked to bring a short write-up concerning 2010 activities and/or 2011 planning. We intend to publish these in the next newsletter so that all our members are aware of ongoing and future activities. For the newsletter all members are invited to submit articles, anecdotes or photos concerning any aspect of the shooting sports; hunting, technical issues, historical, land access and so forth.

Funding is very important and various ways to accomplish this is open for your ideas. Of course both block and state funding from the

NRA need to be aggressively pursued.

Elections will be finalized as well as potential formation of committees and alternatives to help deal with association activities. Also, we need to attract younger members to our various board positions, especially that encompassing legislative activities.

A "Legislative Shoot" has been set up at Calibers in Albuquerque on the 9<sup>th</sup> of January with a noon start and ending around 5pm. The event is open to all members and especially those with NRA instructor credentials will be needed to help those unfamiliar with firearms.

This year we will have a Member of the Year, a gun raffle as well as a few door prizes.

Please fill out the election form and the annual meeting and lunch reservation form if attending. If you purchase a raffle ticket (most flyers will contain one of leftover tickets) either enclose the amount and stub or bring to the meeting. The drawing will be at the end of the session. Tickets will also be available at the door.

Send election form, annual meeting and/or lunch fees, ticket stub and payment to.

Karma Whelchel, P.O. box 30850, Albuquerque, NM 87190

Anthony Trennel, Pres. NMSSA

### LEGISLATIVE SHOOT

Caliber's Indoor Shooting Range, Sunday, January 9, 2011.

If attending please **RSVP** to [karmaw@howardcpa.com](mailto:karmaw@howardcpa.com) or [ttrennel@msn.com](mailto:ttrennel@msn.com)

### INTERESTED IN ONE OF THESE POSITIONS?

Vice President / Black Powder Target Rifle Director / Gun Collecting /  
Recruitment Shoot Coordinator / Muzzleloading /  
Education and Training Refuse To Be A Victim

**Use the ballot inside and nominate yourself as a write-in candidate.**

# NEW MEXICO SHOOTING SPORTS ASSOCIATION

## 2011 Annual Member Meeting REGISTRATION FORM

PLEASE FILL OUT AND PROMPTLY RETURN THIS OR A COPY OF THIS FORM WITH YOUR CHECK TO:

**NMSSA, PO Box 30850, ALBUQUERQUE, NM 87190-0850**

**SATURDAY, JANUARY 15, 2011, 9:00AM - 2:30PM**

### **RIO RANCHO ELKS LODGE**

1530 BARBARA LOOP SE  
RIO RANCHO, NM 87124

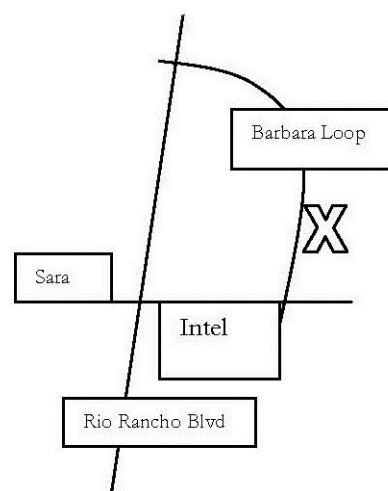

NAME(S) \_\_\_\_\_

ADDRESS \_\_\_\_\_

CITY \_\_\_\_\_ STATE \_\_\_\_\_ ZIP \_\_\_\_\_

PHONE NUMBER \_\_\_\_\_

E-MAIL (PLEASE PRINT) \_\_\_\_\_

NUMBER OF PERSONS ATTENDING \_\_\_\_\_ x \$15.00 EACH = \$ \_\_\_\_\_  
( INCLUDES LUNCH )

NUMBER OF PERSONS ATTENDING \_\_\_\_\_ x \$20.00 EACH = \$ \_\_\_\_\_  
( INCLUDES LUNCH AND 3 TICKETS FOR THE REMINGTON 770 DRAWING )

**TOTAL = \$ \_\_\_\_\_**

**2011 NMSSA EXECUTIVE BOARD**

President	Anthony Trennel	<input type="radio"/>	Vice President	<input type="radio"/>
		<input type="radio"/>		<input type="radio"/>
Treasurer	Karna Whelchel	<input type="radio"/>	Recording Secretary	Carlton Talbot
		<input type="radio"/>		<input type="radio"/>
Membership Secretary	Ken Laintz	<input type="radio"/>		
		<input type="radio"/>		

**2011 NMSSA OFFICERS**

Black Powder Target Rifle Director		<input type="radio"/>	Class III Firearms	Rodney Keith	<input type="radio"/>
		<input type="radio"/>			<input type="radio"/>
CMP Coordinator	William Swantner	<input type="radio"/>	Conservation & Hunting	Dave Bernd	<input type="radio"/>
		<input type="radio"/>			<input type="radio"/>
Cowboy Action	Roy Clouse	<input type="radio"/>	Education & Training (ET)	Coralie Carrier	<input type="radio"/>
		<input type="radio"/>			<input type="radio"/>
ET Eddie Eagle	Paul Rockhold	<input type="radio"/>	ET Refuse To Be A Victim		<input type="radio"/>
		<input type="radio"/>			<input type="radio"/>
ET Women on Target	Leilani McGranahan	<input type="radio"/>	Recruitment Shoot Coordinator		<input type="radio"/>
		<input type="radio"/>			<input type="radio"/>
Gun Collecting		<input type="radio"/>	Gun Show Coordinator	Bob Whelchel	<input type="radio"/>
		<input type="radio"/>			<input type="radio"/>
High Power Rifle	Bob Rodolph	<input type="radio"/>	Junior Activities - Youth	William E. Barker	<input type="radio"/>
		<input type="radio"/>			<input type="radio"/>
Junior Activities - YHEC	Rick Andes	<input type="radio"/>	Law Enforcement	John Stocum	<input type="radio"/>
		<input type="radio"/>			<input type="radio"/>
Legislative Affairs	Paul Lisle	<input type="radio"/>	Life Member Trustee - 3 Year	William Swantner	<input type="radio"/>
		<input type="radio"/>			<input type="radio"/>
Life Member Trustee - 5 Year	Hugh Hambric (2012)		Muzzleloading		<input type="radio"/>
					<input type="radio"/>
Newsletter Editor	Dean Armstrong	<input type="radio"/>	NRA Field Rep	Peter Ide	
		<input type="radio"/>			
NRA / ILA	Tara Mica		Pistol	Tom Shumaker	<input type="radio"/>
					<input type="radio"/>
Shotgun	Damian H. Lusch Sr.	<input type="radio"/>	Silhouette Shooting	Ron Stryker	<input type="radio"/>
		<input type="radio"/>			<input type="radio"/>
Smallbore Rifle	Virginia McLemore	<input type="radio"/>	Web Page Administrator	Dean Armstrong	<input type="radio"/>
		<input type="radio"/>			<input type="radio"/>

# NMSSA 2011 Election Ballot

Please Vote for one person in each

Web Page Administrator	Dean Armstrong	<input checked="" type="radio"/>
		<input type="radio"/>

Or write in your own candidate.

Web Page Administrator	Dean Armstrong	<input type="radio"/>
	James Smith	<input checked="" type="radio"/>

Please mail completed ballots to:

**NMSSA, P.O. Box 30850  
Albuquerque, NM 87190,**

Or bring your ballot with you to the Annual Meeting.

RETURN TO THE MEMBERSHIP SECRETARY  
Ken Laintz PO Box 753 Los Alamos, NM 87544

One Year Annual Membership	\$25.00	Annual Junior, Under Age 19	\$5.00
Life Membership	\$250.00	Annual Club Affiliation	\$25.00
Senior Life Membership	\$100.00		

Please check here if you are renewing your membership

NAME \_\_\_\_\_ DATE OF APPLICATION \_\_\_\_\_  
ADDRESS \_\_\_\_\_ (BUSINESS NAME) \_\_\_\_\_  
CITY \_\_\_\_\_ STATE \_\_\_\_\_ ZIP \_\_\_\_\_  
HOME PHONE \_\_\_\_\_ WORK PHONE \_\_\_\_\_ FAX \_\_\_\_\_  
E-MAIL (PLEASE PRINT) \_\_\_\_\_  
TYPE MEMBERSHIP APPLYING FOR \_\_\_\_\_ AMOUNT ENCLOSED \_\_\_\_\_  
DO YOU BELONG TO YOUR LOCAL CLUB? \_\_\_\_\_ CLUB NAME \_\_\_\_\_  
ARE YOU AN NRA MEMBER? \_\_\_\_\_

**PLEASE MAKE CHECKS PAYABLE TO: NEW MEXICO SHOOTING SPORTS ASSOCIATION**

Email questions to [MembershipSecretary@nmssa.org](mailto:MembershipSecretary@nmssa.org)

**VISIT OUR WEBSITE** <http://www.nmssa.org>

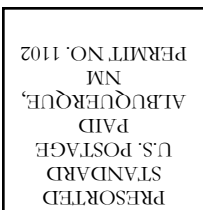

**We're on the Web!**  
[www.nmssa.org](http://www.nmssa.org)

PO Box 753  
Los Alamos, NM 87544

